

DO NOT SCALE-IF IN DOUBT ASK

ITEM NO.	QTY.	DWG/PART No.	MATERIAL	DESCRIPTION
1	2	-	PE610g-FR-PVC, BS 7837-1996, YELLOW	PLASTIC COVER, OUTER
2	6	-	BS EN 12588	LEAD SHEET, 1mm THK
3		2A/6, 2C/6	BRASS	GROMMET EYELET AND WASHER
4	1	Label	SEE DRAWING	LABEL

FOR ITEM 3 SEE TABLE FOR QTY

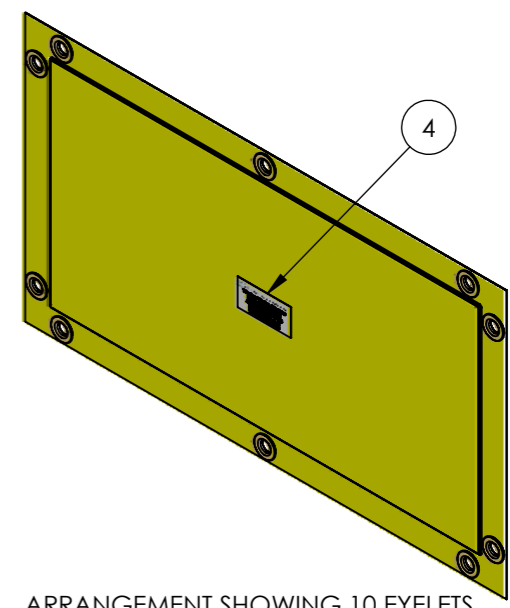
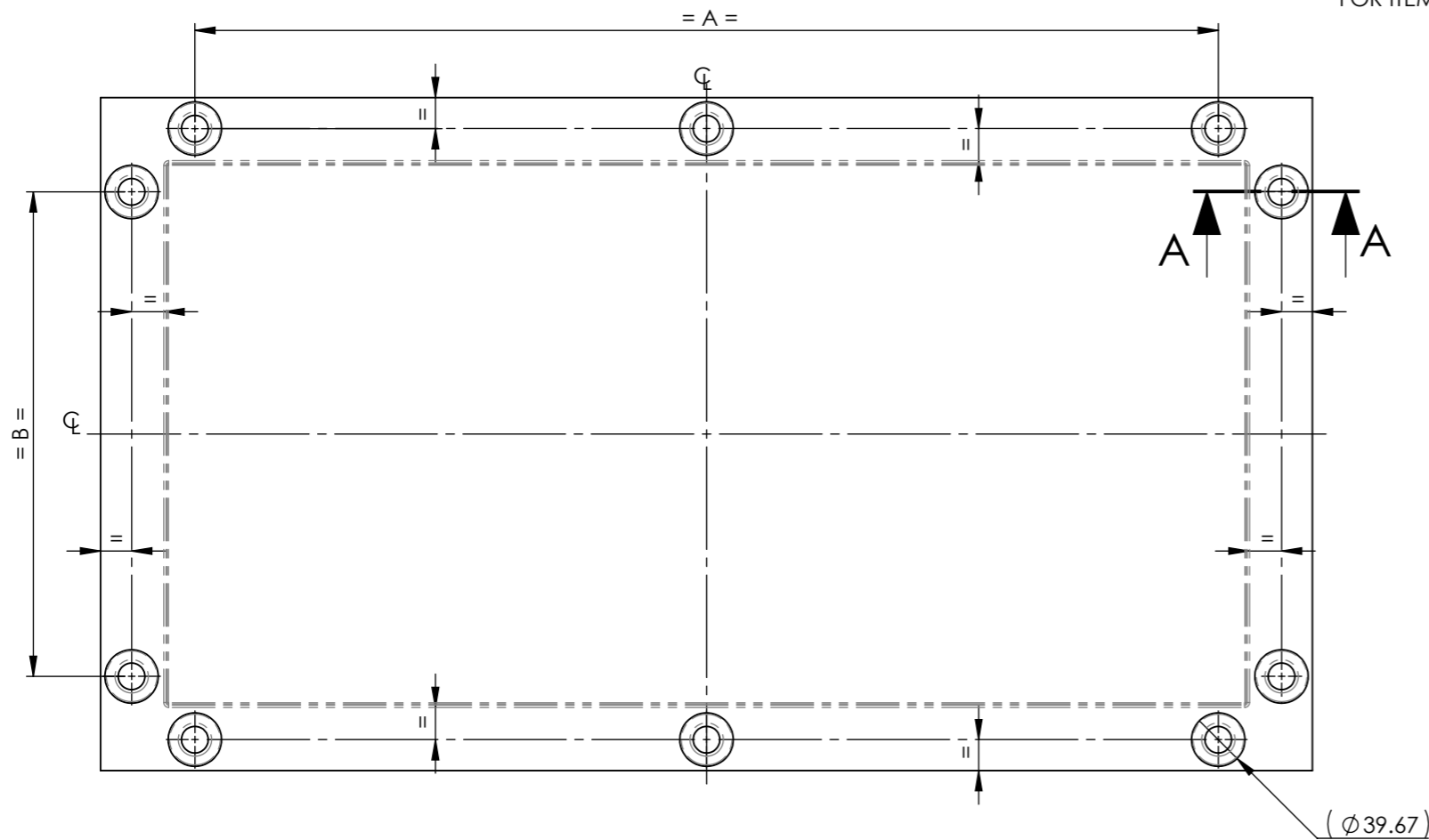

ARRANGEMENT SHOWING 10 EYELETS

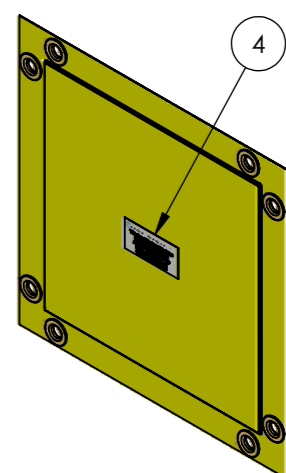

ARRANGEMENT SHOWING 08 EYELETS

SHEET SIZE	LEAD SIZE	A	B	NO. OF EYELETS (ITEM 3)	APPROX. WEIGHT (kg)
900 x 500	800 x 400	760	360	10	22
750 x 450	650 x 350	610	310	10	15
500 x 500	400 x 400	360	360	08	11

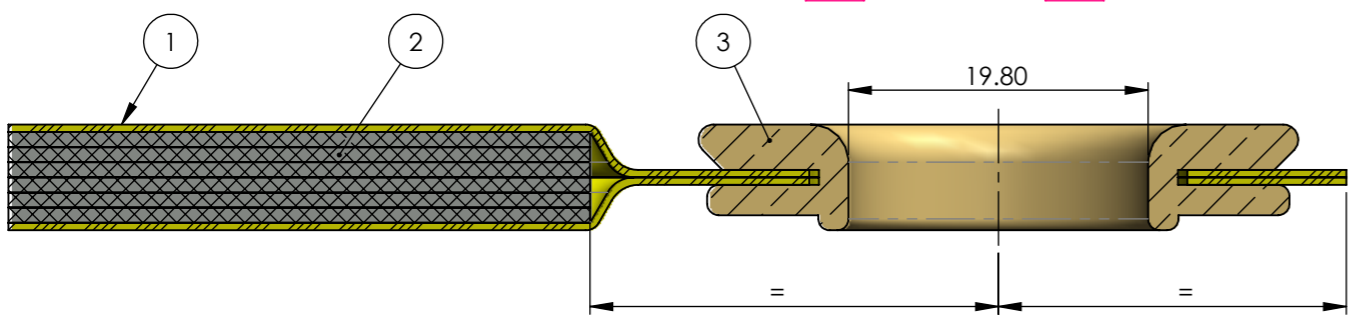

SECTION A-A
SCALE 2 : 1

NOTES:

- TOLERANCE ON LEAD THICKNESS: ±5%
- TOLERANCE ON LEAD CUT EDGES: -2mm +0mm
- LEAD EDGES MUST BE CUT SQUARE
- TOLERANCE FOR LENGTHS A AND B: -3mm +3mm
- TOLERANCE FOR SHEET SIZE: -3mm +3mm
- SWL: 100kg PER EYELET

REV.	DESCRIPTION	APPROVED	DATE
04	LEAD SIZE 650 x 350 WAS 610 x 310. DIM 'A' 610 WAS 650. DIM 'C' 310 WAS 350.	R SEARS	09/11/2017
03	GROMMET EYELET AND WASHER SIZE UPDATED. ADDED WEIGHT TO TABLE.	R TURNER	30/11/2015
02	LAYOUT UPDATED. SHEETS 2 AND 3 REMOVED.	R TURNER	20/11/2015
01	DIMENSIONS UPDATED. ITEM 3 REVISED. SHEETS 2 & 3 ADDED.	JB LLOYD	17/11/2015

THIS DOCUMENT INCLUDING THE COPYRIGHT THEREIN IS THE EXCLUSIVE PROPERTY OF CALDER INDUSTRIAL MATERIALS, CHESTER, UK. IT MAY ONLY BE USED FOR THE PURPOSE FOR WHICH IT WAS ISSUED. IT MAY NOT BE DUPLICATED IN ANY WAY, NOR TRANSMITTED TO ANY THIRD PARTY WITHOUT THE EXPRESS PERMISSION OF CALDER INDUSTRIAL MATERIALS.

GEN. TOLERANCE UNLESS OTHERWISE STATED: ISO 2768-mK
SUR. FIN: -
LEAD THICKNESS TOLERANCE: -0/+0.5

SCALE: 1:5
ALL DIMENSIONS IN mm UNLESS OTHERWISE STATED

TITLE: LEAD BLANKET

DRAWN	D.PARRY	30/09/15
CHECKED	J.DARLINGTON	30/09/15
APPROVED	D.PARRY	01/10/15

DRAWING No. CSPM0037
PROJECT No. N/A
REV 04

Jupiter Drive, Chester West Employment Park, Chester, CH1 4EX. Tel. No. 01244 390093